

Portable Pulper Ragger Tail Cutter

Model 3040 NCT

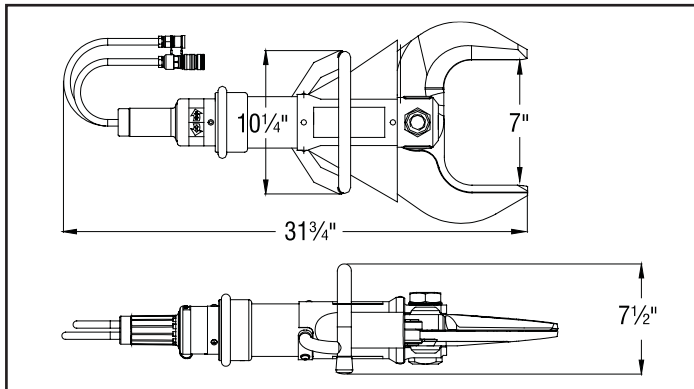

**NFPA 1936
Compliant**



The Thomas Company and Holmatro, Inc have teamed up to rescue recyclers from the difficulty associated with disposal of a continuous pulper ragger tail.

Utilizing the hydraulic shears commonly used to rescue an accident victim from a wrecked vehicle has proven to be a safe, cost effective means to cut the tail into manageable lengths.

Find out how to cut ragger tails at a fraction of the cost of a stationary ragger cutter and without the danger associated with cutting with a steel power saw or a torch.

Ask your Thomas Co. representative for a demonstration of this equipment and a budget price.

Illinois, Indiana, Kentucky, Ohio

Dave Hendrickson - 269-760-6689cell

Michigan, Minnesota, Wisconsin

Pete Thomas, 269-339-0506cell

Maryland, North Carolina, South Carolina, Virginia

John Craft, 715-340-8382cell

Wisconsin, Minnesota, UP-Michigan

Tom Flanders, 715-340-8382cell



Made in USA



Holmatro, Inc. • 505 McCormick Drive • Glen Burnie, MD 21061
Tel: 410-768-9662 • Fax: 410-768-4878 • e-mail: info@holmatro-usa.com

Holmatro® is an ISO 9002 registered company. • Holmatro® is a registered trademark of Holmatro, Inc. • © Holmatro, Inc. 2003

PJT

The Peter J. Thomas Company, Inc.
471 West South Street
Kalamazoo, MI 49007
Tel: (269) 344-4552
Fax: (269) 344-6661